

## VOU-Series

### Features and Strengths

- Best suitable for handling long objects with flat and curved surfaces
- Good lifting forces can be achieved with small size
- Conductive silicon is excellent for handling PCB board or Electronic componets
- Easily mountable without detach a fitting from the machine (save the maintenance time)

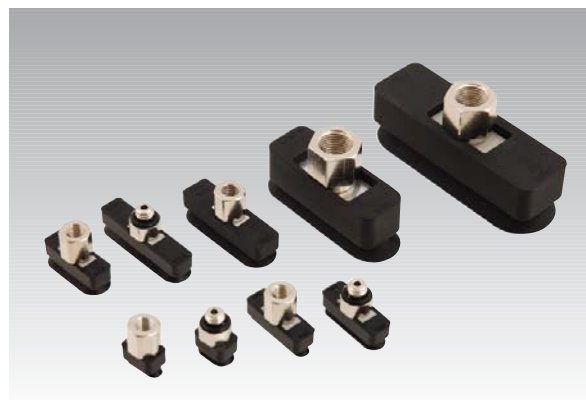

### Suitable for Handling

- Semiconductor Chips (PCB board)
- Electronic components
- Small glass cases (e.g. ampule)
- Pipe

### Order No.

**VOU 15X45 N F 18F - L1820TN**

①

②

③

④

⑤

▶ See pages 78-83.

#### ① Vacuum pad Ø

VOU 4 X 10

VOU 4 X 20

VOU 6 X 10

VOU 6 X 20

VOU 8 X 20

VOU 8 X 30

VOU 10 X 30

• **VOU 15 X 45**

VOU 20 X 60

#### ② Material

• **N** – NBR

S – Silicon

WS – White Silicon

CS – Conductive (Special mat'l)

U – Urethane

#### ③ Filter

• No Mark – Standard

F\* – With mesh filter

\* Only for VOU 15x45  
VOU 20x60

#### ④ Fitting thread

M5M – M5 X 0.8 Male VOU 4X10, 4X20, 6X10, 6X20

M5F – M5 X 0.8 Female 8X20, 8X30  
10X30

18M – G1/8" Male

• **18F** – G1/8" Female VOU 15X145, 20X60

#### ⑤ Level spring (Accessory)

L507TN – VOU 4X10, 4X20, 6X10, 6X20, 8X20, 8X30, 10X30

• **L1820TN** – VOU 15X45, 20X60

### Recommended (max.) lifting forces

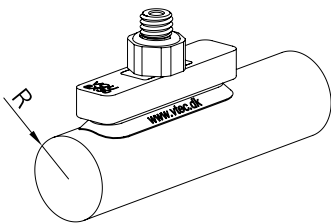

Model	Lifting Force (kg) -Perpendicular	Internal volume (cm <sup>3</sup> )	Min.curvature radius R (mm)	Weight ≐ (Kg)
VOU 4X10 -...	0,205	0,064	3,5	0,00031
VOU 4X20 -...	0,347	0,094	3,5	0,00036
VOU 6X10 -...	0,256	0,081	4,5	0,00031
VOU 6X20 -...	0,603	0,137	4,5	0,00037
VOU 8X20 -...	0,818	0,17	6,5	0,00037
VOU 8X30 -...	1,053	0,25	6,5	0,00043
VOU 10X30-...	1,554	0,394	8	0,00047
VOU 15X45 -...	3,271	1,584	11	0,022
VOU 20X60 -...	6,352	3,532	17	0,031

### Dimensional information

#### ▼ VOU 4X10 ~ 8X30

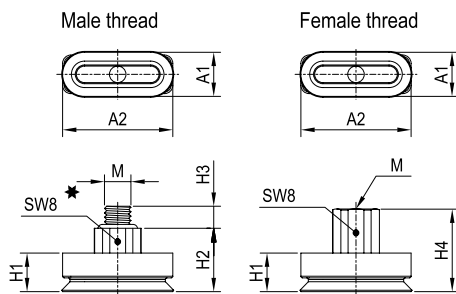

#### ▼ VOU 15X45, 20X60

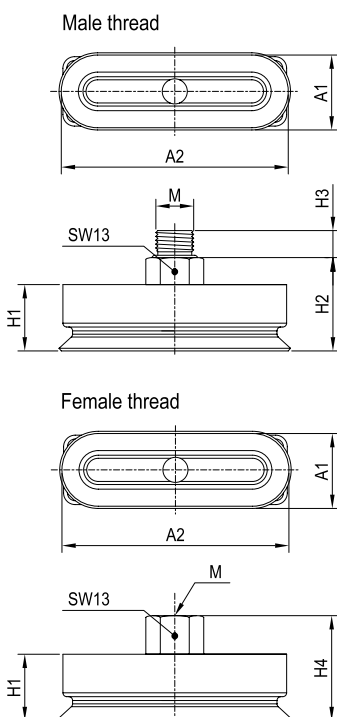

Model	A1	A2	H1	H2	H3	H4	M
VOU 4 x 10..M5M	4	10	7	11.5	4	-	M5 x 0.8
VOU 4 x 10..M5F				-	-	15	M5 x 0.8
VOU 4 x 20..M5M	4	20	7	11.5	4	-	M5 x 0.8
VOU 4 x 20..M5F				-	-	15	M5 x 0.8
VOU 6 x 10..M5M	6	10	7	11.5	4	-	M5 x 0.8
VOU 6 x 10..M5F				-	-	15	M5 x 0.8
VOU 6 x 20..M5M	6	20	7	11.5	4	-	M5 x 0.8
VOU 6 x 20..M5F				-	-	15	M5 x 0.8
VOU 8 x 20..M5M	8	20	7	11.5	4	-	M5 x 0.8
VOU 8 x 20..M5F				-	-	15	M5 x 0.8
VOU 8 x 30..M5M	8	30	7	11.5	4	-	M5 x 0.8
VOU 8 x 30..M5F				-	-	15	M5 x 0.8
VOU 10 x 30..M5M	10	30	8.2	12.7	4	-	M5 x 0.8
VOU 10 x 30..M5F				-	-	16.2	M5 x 0.8
VOU 15 x 45..18M	15	45	15.5	23	7	-	G1/8"
VOU 15 x 45..18F				-	-	25.5	G1/8"
VOU 20 x 60..18M	20	60	17.5	25	7	-	G1/8"
VOU 20 x 60..18F				-	-	27.5	G1/8"