

## Series VSM..

- Max. vacuum level : -26.57 inHg (-90kPa)
- Max. flow rate : 3.03 scfm (85.8 NI/min)
- Supply air pressure : 43.5~87 psi, max 101.5psi (3~6bar, max 7bar)
- Air consumption : 0.7~1.13 scfm (20~32 NI/min)
- Supply air type : Dry compressed air
- Working temperature : -4 °F ~ 176 °F
- Noise level : 55~65 dBA



## Main advantages

- Efficient individual and independent point-of-use vacuum.
- Extremely quick response.
- Multiple connection ports available
- Maintains vacuum despite fluctuations and drops in air pressure.
- VMECA TWOFOLD SILENCER<sup>PT</sup> assures low noise levels. (about 30% lower than conventional silencer)

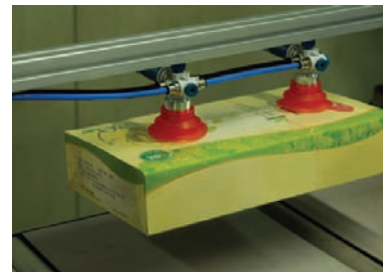

## Order No.

### VSM 203 - PT8..VBF80 PU - 38M

▲ See pages 81-95

①

②

#### ① Vacuum cartridge

203	- Vacuum cartridge VC203 incl. twofold silencer	
203 N	- Vacuum cartridge VC203 with non-return valve incl. twofold silencer	
• 202	- Vacuum cartridge VC202 incl. holding plug	
202 N	- Vacuum cartridge VC202 with non-return valve incl. holding plug	
020	- No vacuum cartridge (slave unit)	

#### ② Mount and mounting position

F	- 4x screw M4 top, 5x plug G1/8" (direct mount)	
MT8	- M8 16mm screw top, 4x plug G1/8" incl. mounting kit	
ML8	- M8 16mm screw left, 4x plug G1/8" incl. mounting kit	
MR8	- M8 16mm screw right, 4x plug G1/8" incl. mounting kit	
• PT8	- M8 27mm screw top, 4x plug G1/8" incl. profile kit with jam nut	
PL8	- M8 27mm screw left, 4x plug G1/8" incl. profile kit with jam nut	
PR8	- M8 27mm screw right, 4x plug G1/8" incl. profile kit with jam nut	
PT6	- M6 22mm screw top, 4x plug G1/8" incl. profile kit with jam nut	
PL6	- M6 22mm screw left, 4x plug G1/8" incl. profile kit with jam nut	
PR6	- M6 22mm screw right, 4x plug G1/8" incl. profile kit with jam nut	

Technical Data

Model	Feed pressure (psi)	Air consumption (scfm)	Max. Vacuum level (-inHg)	Suction cup	Time, s/l, evacuate a volume to different vacuum level	
					-5.9 inHg	-17.7 inHg
VSMR 203.. VSM 203..	45.5	0.918	26.5	VB 30..	0.05	0.09
				VB40..	0.06	0.1
				VB50..	0.07	0.12
				VB75 (B)..	0.15	0.22
				VBF 30..	0.05	0.08
				VBF 40..	0.05	0.09
				VBF 50..	0.06	0.1
				VBF 60..	0.08	0.12
				VBF 80..	0.14	0.18
				VBF 100..	0.17	0.2
				VBL 30..	0.05	0.09
				VBL 40..	0.08	0.12
				VBL 50..	0.1	0.14
				VF 30..	0.04	0.07
				VF 40..	0.04	0.07
				VF 50..	0.05	0.08
				VF 75..	0.06	0.11
				VF 90..	0.07	0.12
				VF 110..	0.11	0.17
				VFC 50..	0.05	0.09
				VFC 60..	0.06	0.11
				VFC 75..	0.08	0.13
				VFC 90..	0.11	0.18
				VFC 100..	0.13	0.2
				VOU 15X45..	0.04	0.07
				VOU 20X60..	0.05	0.08
VOC 35X90..	0.06	0.11				
VOC 35X110..	0.07	0.13				
VOC 60X140..	0.13	0.15				
VOC 60X180..	0.16	0.18				
VSMR 202.. VSM 202..	45.5	0.918	26.5	VB 30..	0.06	0.09
				VB 40..	0.07	0.1
				VB 50..	0.08	0.13
				VB 75 (B)..	0.17	0.25
				VBF 30..	0.05	0.08
				VBF 40..	0.05	0.09
				VBF 50..	0.06	0.11
				VBF 60..	0.08	0.13
				VBF 80..	0.16	0.21
				VBF 100..	0.2	0.26
				VBL 30..	0.06	0.1
				VBL 40..	0.08	0.13
				VBL 50..	0.1	0.16
				VF 30..	0.04	0.07
				VF 40..	0.04	0.08
				VF 50..	0.05	0.09
				VF 75..	0.06	0.11
				VF 90..	0.07	0.12
				VF 110..	0.12	0.19
				VFC 50..	0.05	0.09
				VFC 60..	0.06	0.12
				VFC 75..	0.09	0.14
				VFC 90..	0.11	0.2
				VFC 100..	0.14	0.21
				VOU 15X45..	0.04	0.07
				VOU 20X60..	0.05	0.08
VOC 35X90..	0.06	0.12				
VOC 35X110..	0.07	0.14				
VOC 60X140..	0.15	0.2				
VOC 60X180..	0.17	0.22				

VACUUM SPEEDER

Dimension

▼ VSMR 203..

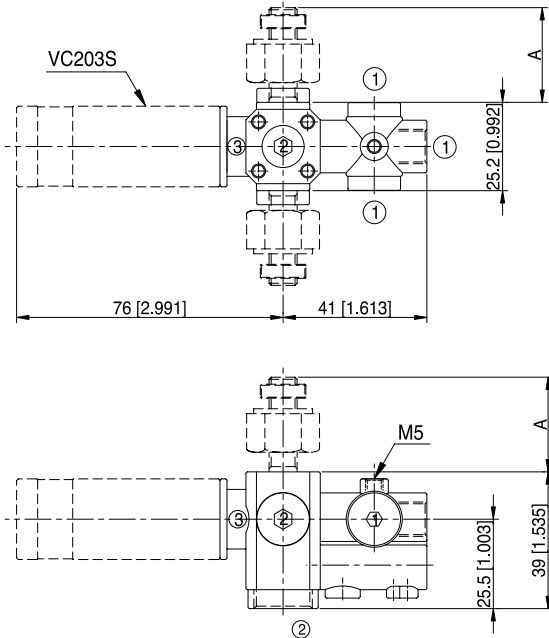

▼ VSM 203..

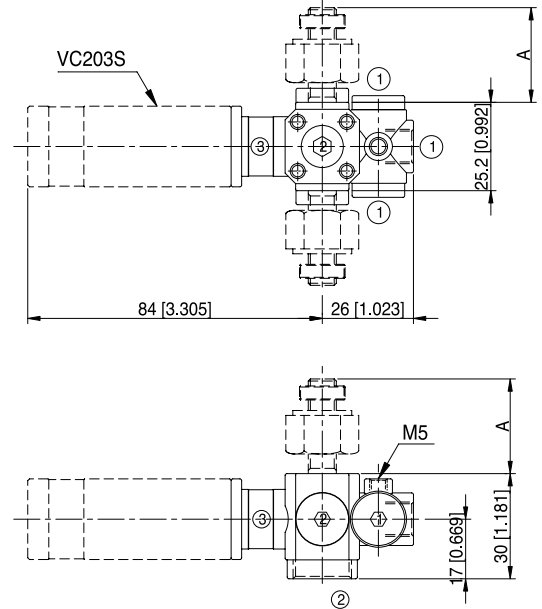

Measure unit : mm [inch]

Mounting	A
M□8	0.63"
P□8	1.06"
P□8	0.86"

1. Compressed air : 3 x G1/8"
2. Vacuum : 1 x G3/8" and 3 x G1/8"
3. Exhaust

▼ VSMR 202..

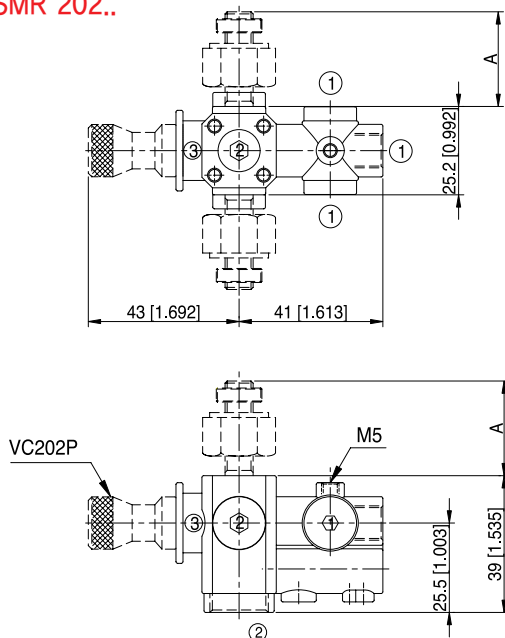

▼ VSM 202..

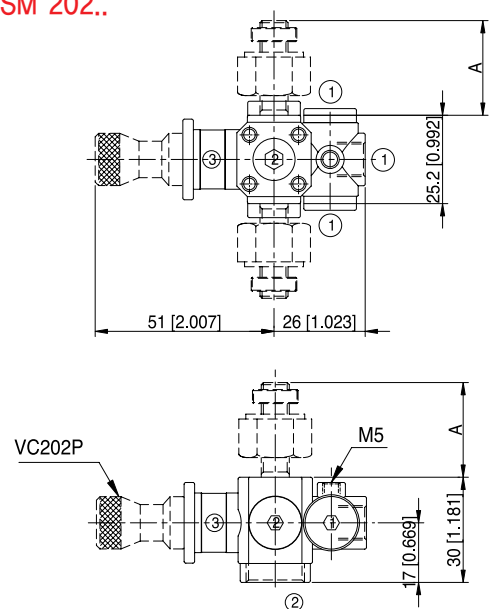

Measure unit : mm [inch]

Mounting	A
M□8	0.63"
P□8	1.06"
P□8	0.86"

1. Compressed air : 3 x G1/8"
2. Vacuum : 1 x G3/8" and 3 x G1/8"
3. Exhaust

Refer to page 81~95 about dimension of suction cups.

## How to select Suction cup



Suction cup	Shape			Requirements							
	Flat	Slightly surface	Concave surface	Smooth surface	Uneven surface	Varying surface levels	Thin flexible materials	Good stability	Safety	Parallel lift	Opening plastic bag
VB	★★	★★★★		★★★★		★★★★	★★★★	★	★★★★	★	★★
VPF	★★★★	★★★★	★	★★★★		★★★★	★★★★	★★★★	★★★★	★★★★	
VBL	★★	★★★★		★★★★		★★★★	★★★★		★★		
VF	★★★★			★★★★				★★★★	★★★★	★★★★	
VFC	★★★★	★★★★		★★★★	★			★★★★	★★★★	★★★★	★
VOU	★★★★	★★	★★	★★★★				★★	★★	★	
VOC	★★★★	★★★★		★★★★		★		★★★★	★★★★	★★★★	

★★★★ Excellent   ★★ Very good   ★ good



Slightly curved surface  
**VB model**

▶ See page 82

Thin flexible material  
**VBL model**

▶ See page 86

Sheet metal  
**VPF model**

▶ See page 84

Transferring to parallel  
**VF, VFC model**

▶ See page 88,90

Long convex or flat  
**VOU model**

▶ See page 92

Long flat  
**VOC model**

▶ See page 94

## Material and characteristic of suction cup

Material	Durability	Temperature	Oil Resistance	Weather & Ozone
N - NBR	Excellent	-40 °F ~ +230 °F	Excellent	Very Good
S - Silicon	Good	-94 °F ~ +392 °F	Unsuitable	Excellent
C.S - Conducive(Special mat'l)	Excellent	-49 °F ~ +194 °F	Excellent	Very Good
U - Urethane	Excellent	-4 °F ~ +185 °F	Excellent	Excellent
A - Mark free	Excellent	-40 °F ~ +176 °F	Excellent	Very Good
PU - Poly Unethane	Excellent	32 °F ~ +140 °F	Excellent	Excellent
E - EPDM	Very Good	-40 °F ~ +212 °F	Unsuitable	Excellent